



Mobile Systems M

Alma Mater Studiorum – University of Bologna
CdS Laurea Magistrale (MSc) in
Computer Science Engineering
II Term – Academic Year 2022/2023

Mobile Systems M (8 ECTS)

Paolo Bellavista

paolo.bellavista@unibo.it

<http://lia.disi.unibo.it/Courses/sm2223-info/>

Or only on virtuale.unibo.it ?

<https://www.unibo.it/sitoweb/paolo.bellavista>



Mobile Systems M in a Single Slide

Pre-requisites: **none**

But the contents of the “old” courses of computer networks (Reti di Calcolatori T and, even if partially, Infrastructures for Cloud Computing and Big Data M), Sistemi Operativi T, and Tecnologie Web T are ***certainly useful***

Examination modes: long 😊 oral exam (with the possible discussion of a personal project – optional; also opportunity of Project Activity for 4 ECTS)

Course Goals (in extremely short): in-depth competence on models and solutions for ***state-of-the-art mobile systems***, for ***mobile services and applications*** provisioned on top of them, and for the ***support (middleware)*** needed for the development and ***runtime management*** of them. Know-how about ***methodologies, models, technologies, and implementations*** to ***design, implement, deploy, and runtime evaluate*** mobile services



Mobile Systems M: Output Skills and Abilities (1)

Output skills and abilities:

- ❑ ***Supplements of mobile communications, networking, and systems***
 - introductory elements of propagation and fading models
 - overview of primary characteristics of ***IEEE 802.11*** (infrastructured, ad hoc – WiFiDirect - and mesh-oriented)
 - overview of primary characteristics of ***cellular networking***
 - overview of primary characteristics of ***IEEE 802.15***
 - ***mobile ad hoc networks*** (MANET) and their ***routing protocols***
 - ***mobility management***, Mobile IP, iTCP, and positioning ***techniques***

- ❑ ***The mobile middleware concept***
 - ***platform examples***, with in-depth technical presentation of Android features and programming model
 - ...



Mobile Systems M: Output Skills and Abilities (2)

- ❑ ***The mobile middleware concept***
 - ***support technologies*** (SIP, edge cloud, 5G infrastructure, discovery in mobile environments, ...)
 - advanced topics such as ***context awareness, service composition, and overlay networking***
 - ***publish/subscribe***
 - ***data synchronization***

- ❑ ***Application areas and domain-specific deployment environments and situations***

More «traditional» such as

 - location-aware and context-aware services
 - context management and smart spaces

...



Mobile Systems M: Output Skills and Abilities (3)

□ *Application areas and domain-specific deployments*

Or more «visionary» such as

- vehicular networks and applications, Delay Tolerant Networking, opportunistic networking
- efficient integration mobile-to-cloud, cloudlet, fog computing, edge computing, virtualization and «containerization»
- **quality of information and sensed data in Internet-of-Things**, Value of Information
- **edge/fog computing for Industry4.0** manufacturing production lines, predictive/prescriptive maintenance, machine reconfiguration under strict latency constraints, federated machine learning, ...
- cooperative autonomous driving (fleet-oriented), collaborative object detection, ...
- ...



Mobile Systems M: Output Skills and Abilities (4)

In addition, the course will include:

- ❑ a few ***guided lab exercises*** about some topics and technologies described during lectures (horizontal and vertical handoff, Android, location-dependent services and positioning, Internet of Things management, cloudlets, ...). These exercises will be solved autonomously by the students, with the support and supervision of the teacher; they will exploit advanced simulation environments (e.g., ns-2/ns-3 and SUMO) and Android/Raspberry PI devices
- ❑ discussion of ***real/realistic case studies***, in particular in the application domains of ***location/context-aware services, efficient IoT-edge-cloud integration, and edge-enabled industrial IoT***
- ❑ possible additional ***seminars*** to present significant ***company case studies***



Mobile Systems M: Exam Modes and Dates

The exam will consist of:

- ❑ a **LONG oral interview**, of course 😊 about the WHOLE technical programme of the course
- ❑ an optional discussion of **a self-developed optional project** (guided and negotiated with the teacher) on the design and implementation of middleware/applications that employ some technologies of primary interest for the course

The project, of course of **greater complexity in the case** 😊, can be associated with a Project Activity (4 ECTS)

Exam dates (additional dates will be available at <http://almaesami.unibo.it>,

where it is necessary to register for exams):

- ❑ First date – **June 22, 2023**, 9:00am, meeting at the teacher's office
- ❑ Second date – **July 7, 2023**, 9:00am, meeting at the teacher's office
- ❑ Third date – **July 24, 2023**, 9:00am, meeting at the teacher's office



Teaching Material

- ❑ **Slides** used during lecturing and during guided lab exercises (available for download from the course Web site; the slides will be uploaded progressively as advancing in the topics presentation)

- ❑ **Suggested Textbooks:**
 - S. Tarkoma, *Mobile Middleware*, Wiley, 2009
 - A. Ravulavaru, *Enterprise Internet of Things Handbook*, Packt, 2018
 - Ke-Lin Du, M.N.S. Swamy, *Wireless Communication Systems*, Cambridge University Press, 2010
 - N. Smyth, *Android Studio 4.2 Development Essentials - Java Edition*, Payload Media, 2021
 - A. Goransson, *Efficient Android Threading: Asynchronous Processing Techniques for Android Applications*, O'Reilly, 2014

- ❑ **Additional on-line sources:**
 - Public tutorials about Android, iOS, ns-3, edgeXfoundry, ...
 - Mobile & Pervasive Computing course, Univ. Carnegie-Mellon; Mobile Computing course, Univ. Ohio; Pervasive Computing course, MIT; Mobile Computing course, Virginia Tech; Mobile Computing and Sensor Networks course, NJIT



Lab Access and Receiving Hours

- ❑ Associated lab for autonomous exercises: **Lab2**
(students can use it anytime the lab is not occupied for lecturing)
Tools and instruments: usual IDEs, with particular emphasis on Android Studio, to develop middleware/applications for **Android and iOS SDK, Ns-3 or Omnet++** (simulators for any-layer protocols), **SUMO** (simulator for vehicular mobility), **real Android and Raspberry PI devices** (a few units 😊...), and a few **Jetson boards**
- ❑ Further development and deployment tools (as well as additional material sources) will be mentioned and described when dealing with the related specific topics
- ❑ **Receiving hours:**
 - Bellavista – Tue 2:00-4:00pm after appointment via email c/o “new” DISI offices – aule nuove building (close to 5.7 seminar room)
 - E-mail: paolo.bellavista@unibo.it



Generally:

- ❑ on Tuesdays, 12:00am - 02:00(1:45)pm
1.5 seminar room
- ❑ on Thursdays, 02:00pm - 05:00(04:45)pm
0.7 seminar room

(any critical overlapping?)

Possible variations will be communicated promptly on virtuale and on the professor's homepage



Mobile Systems M

Let us start in an interactive and provocative way...

- Examples of «interesting and innovative» mobile systems in 2023?
- Which research/work opportunities in mobile systems in 2023?
- Which OPEN research challenges in mobile systems in 2023?



Why a Mobile Systems Course? Marketing Presentation 😊 (1)

When I started this course in 2012, I added some justifications and motivations about:

- ❑ Suitability of acquiring **competences and skills on mobile communications and services, mobile devices, smartphones, ...**
- ❑ **Emerging relevance of mobile wireless IoT and connected vehicles**
- ❑ Suitability of focusing on **Android**

Motivations are still needed 😊 in 2023, after the technological and market evolutions of the last years?

And mobile systems are not only smartphones!





Why a Mobile Systems Course? Marketing Presentation 😊 (2)

- ❑ Market trends in the last 5 years exhibit ***impressive growth of smartphones***
 - Availability of very ***attractive and responsive applications***
 - ❑ Browsers and multimedia players
 - ❑ Augmented/virtual reality, location/context-based services
 - ❑ Social networking apps
 - ❑ Gaming, ...
 - Hardware with ***increasing performance***, e.g., displays and CPUs
 - ❑ Connectivity (4.5/5G/B5G, Wi-Fi, Bluetooth, ...)
 - ❑ GPS, magnetoscopes, gyroscopes, sensors, ..
 - ❑ SSD storage solutions
- ❑ Huge ***mass market***
 - See the following statistics...





Smartphone OS Market

a Picture of 2011, which we probably have forgotten...

In 2011, the global market scenario was already under definition in a quite clear way:

- ❑ If compared with 2010, **sales increased of 42% (previous year of 89%!)**
- ❑ **Android devices** were the champions in sales in the last quarter of 2011 (growth of **615%** between 2010 and 2009)
- ❑ 115M units sold in 3Q11

OS/platform	3Q11 units	3Q11 Market share (%)	3Q10 units	3Q10 Market share (%)
Android	60490400	52.5	20544000	25.3
Symbian	19500100	16.9	29480100	36.3
iOS	17295300	15.0	13484400	16.6
RIM	12701100	11.0	12508300	15.4
Bada	2478500	2.2	920600	1.1
Microsoft	1701900	1.5	2203900	2.7
Others	1018100	0.9	1991300	2.5
Overall	115185400	100	81132600	100

Gartner, Nov. 2011

Source: Canalisys



Smartphone OS Market today

Mobile operating systems' market share worldwide from 1st quarter 2009 to 4th quarter 2022

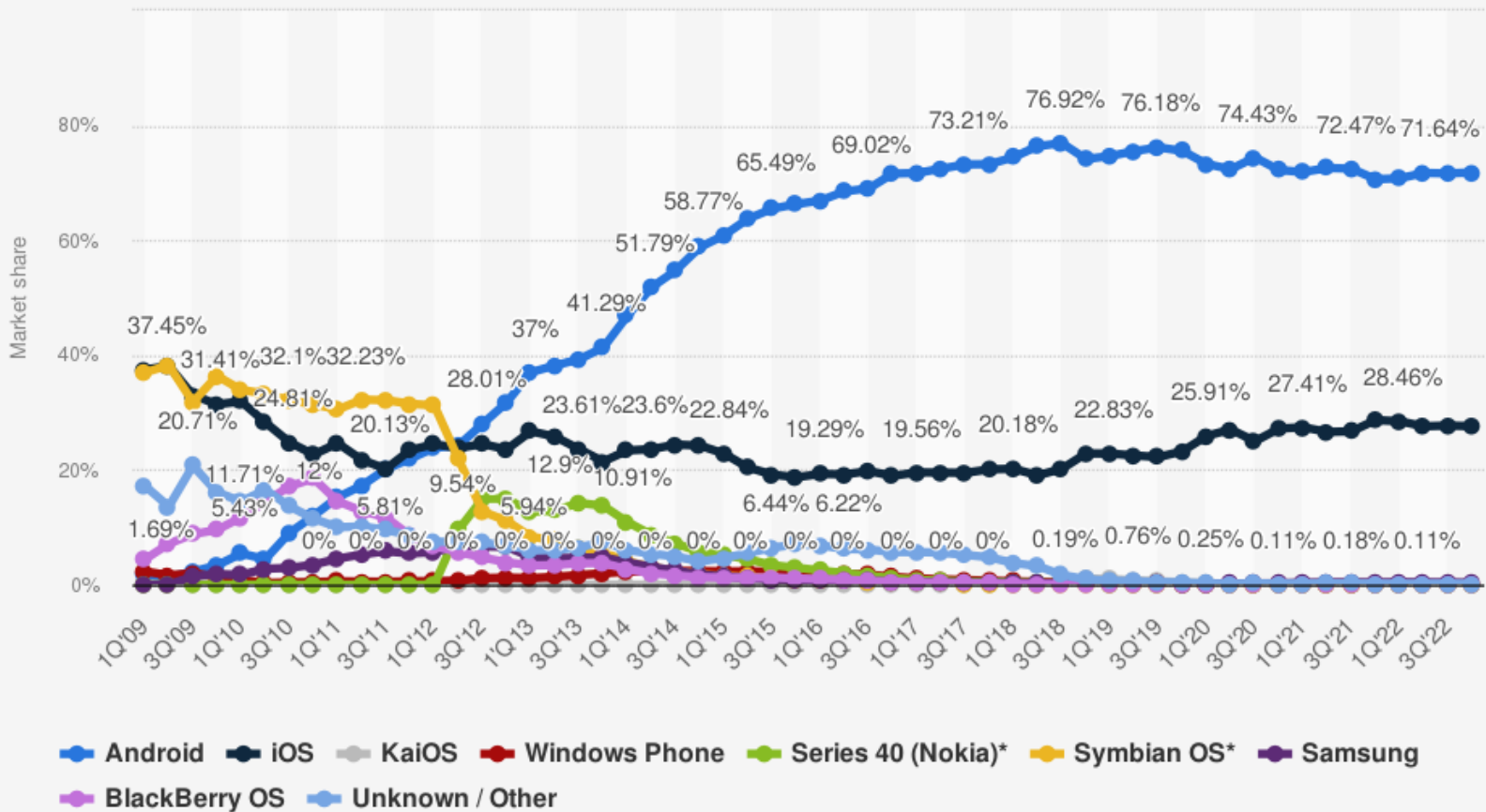

Source
StatCounter
© Statista 2023

Additional Information:
Worldwide; 2012 to 2022



Smartphone OS Market today

Quarterly Global Smartphone Shipments by Key OEM

Q4 2022 Vs Q4 2021
YoY % Change

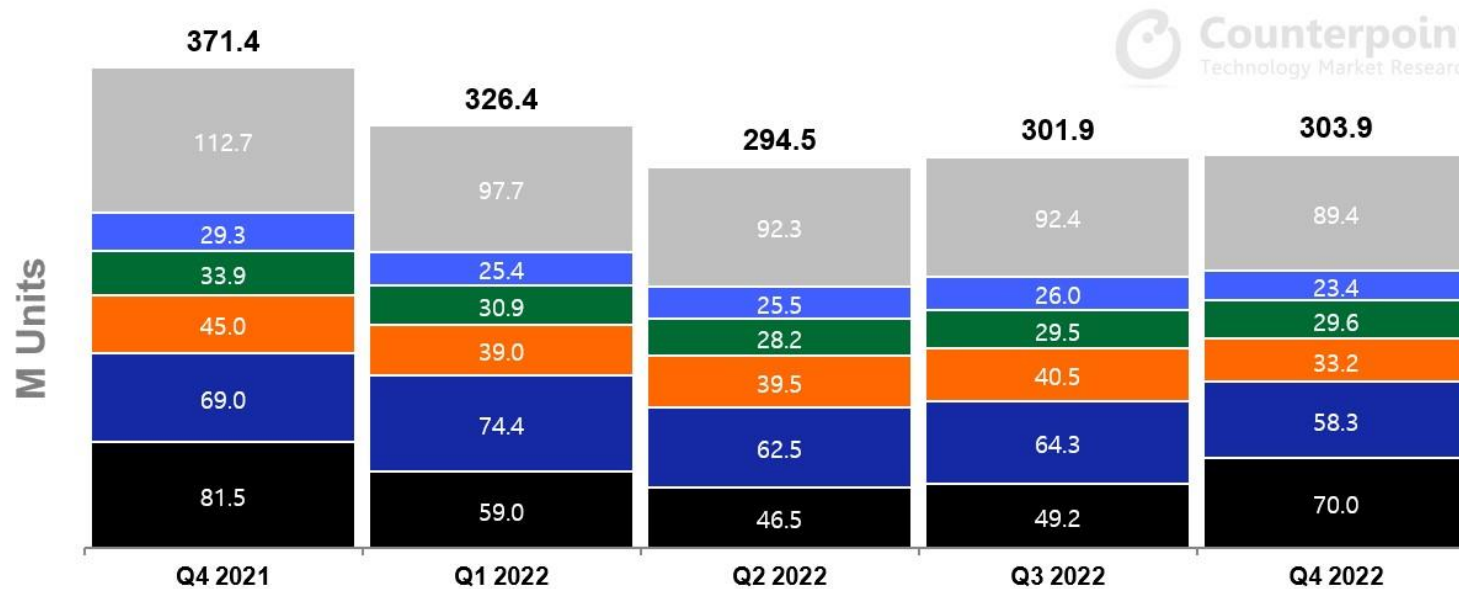

Total	-18%
Others	-21%
vivo	-20%
oppo	-13%
mi	-26%
SAMSUNG	-16%
Apple	-14%

Source: Counterpoint Research Quarterly Market Monitor Prelim data, Q4 2022
Note: OPPO includes OnePlus since Q3 2021



Why a Mobile Systems Course: a bit more technical...

- ❑ Towards a definition of ***mobile computing***, ***context awareness*** and ***middleware***
- ❑ Why mobile computing is NOT AT ALL a commodity but a ***great open opportunity*** for research and business
- ❑ Mobile computing generates ***different requirements*** in design/implementation of middleware and sw applications
- ❑ Examples of highly innovative ***mobile middleware and services***
- ❑ For instance, possible vision: “***federated islands of edge-enabled***, social-aware, context-aware pervasive mobile services”? *Federated learning?*



Mobile Computing (1)

Mobile computing calls for an approach at ***multiple layers and with multiple competences/skills***:

- ❑ Embedded ***devices*** (challenges for miniaturization, reduced energy consumption, ...)
- ❑ ***Wireless*** communications (IEEE 802.11 a/b/g/s/..., Bluetooth, Bluetooth Low Energy (BLE), 5G, vehicular protocols, ...)
- ❑ ***Software support platforms*** (Android, iOS, SymbianOS?, RIM?, Flutter?, React Native?, ...)
- ❑ ***Energy management*** performed at the sw platform layer (middleware, application, ...)
- ❑ ***Management of multiple heterogeneous wireless interfaces and handover*** at the sw platform layer
- ❑ ***Context management***
- ❑ ...



Mobile Computing (2)

- ❑ ...
- ❑ **Cross-layer management** of application requirements and resource allocation
- ❑ Support to **infrastructure-based services**
- ❑ Support to mobile **peer-to-peer, opportunistic, and delay-tolerant services**
- ❑ Support to **mobile social-aware services**
- ❑ Support to **mobile-fog-cloud integrated services in an efficient and smart way** (in particular for the Internet of Things)
- ❑ **And design, implementation, deployment and runtime management** of all these classes of services with differentiated and dynamic requirements!



The example of Proximity Services in Mobile Edge Computing

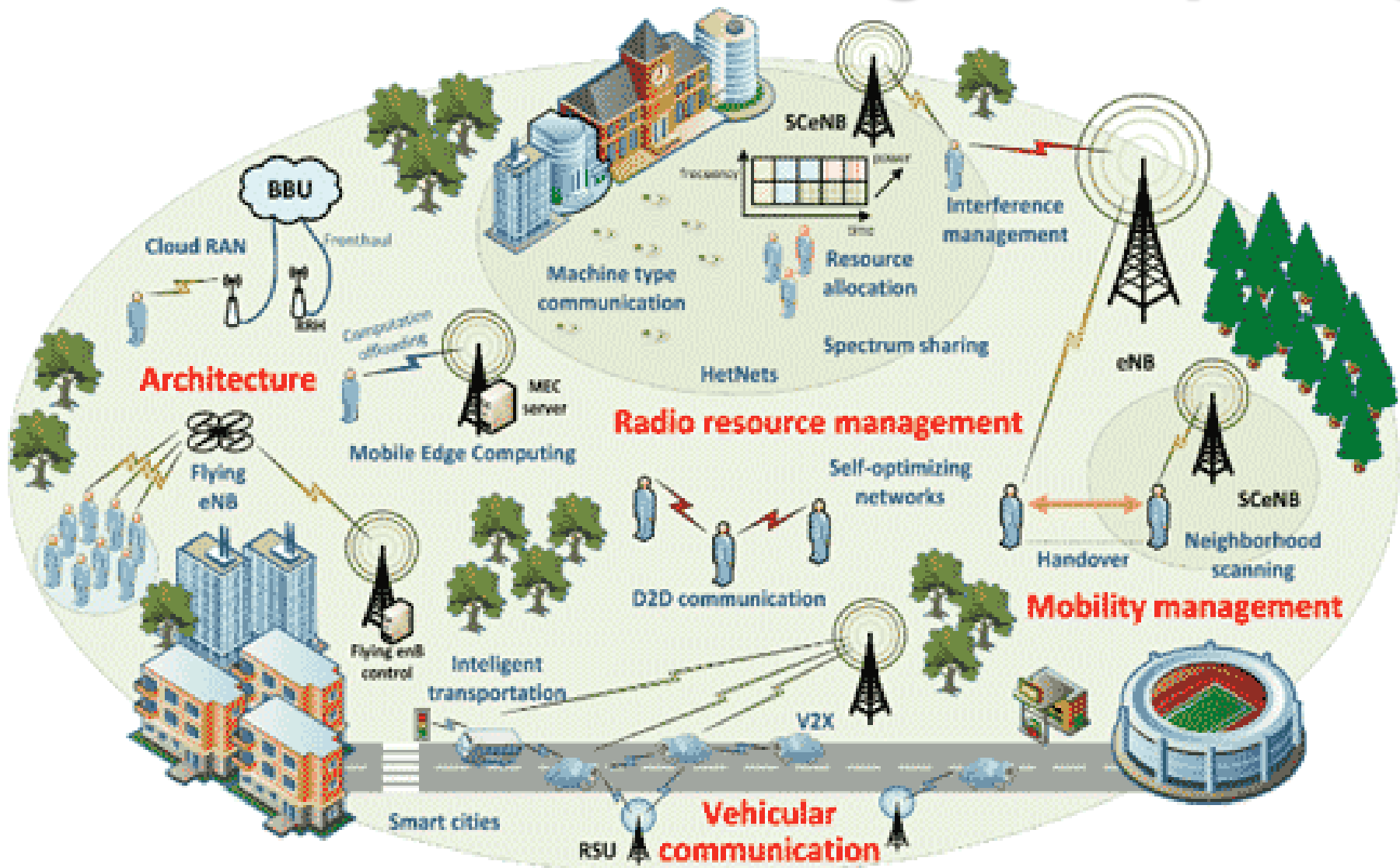



NOT a COMMODITY!

Mobile computing calls for an approach at ***multiple layers and with multiple competences/skills***:

- ❑ Embedded ***devices*** (challenges for miniaturization, reduced energy consumption, ...)
- ❑ ***Wireless*** communications (IEEE 802.11a/b/g/s/..., Bluetooth, Bluetooth Low Energy (BLE), 5G, vehicular protocols, ...)
- ❑ ***Software support platforms*** (Android, iOS, SymbianOS?, RIM?, Flutter?, React Native?, ...)
- ❑ ***Energy management*** performed at the sw platform layer (middleware, application, ...)
- ❑ ***Management of multiple heterogeneous wireless interfaces and handover*** at the sw platform layer
- ❑ ***Context management***
- ❑ ...

MIDDLEWARE



NOT a COMMODITY

- ❑ ...
- ❑ ***Cross-layer management*** of application requirements and resource allocation
- ❑ Support to ***infrastructure-based services***
- ❑ Support to mobile ***peer-to-peer, opportunistic, and delay-tolerant services***
- ❑ Support to ***mobile social-aware services***
- ❑ Support to ***mobile-fog-cloud integrated services in an efficient and smart way*** (in particular for the Internet of Things)
- ❑ ***And design, implementation, deployment and runtime management*** of all these classes of services with differentiated and dynamic requirements!

MIDDLEWARE + APPS



Middleware and Mobile Applications

Only to mention a few possible examples:

- ❑ ***Distribution of dynamically adapted multimedia streaming*** towards differentiated smartphones and mobile terminals
- ❑ ***Always Best Connected*** and ***Always Best Served***
- ❑ ***Sensors, smart environments,*** and associated ***dynamic adaption of context-aware services***
- ❑ ***Collaborative urban monitoring*** (vehicular traffic, pollution, usage of vehicles/users that are intrinsically mobile, ...) – see MobEyes and COLOMBO
- ❑ ***Replication*** and ***delay-tolerant applications***
- ❑ ***Resource sharing based on proximity*** – see RAMP
- ❑ ***Resource sharing*** and ***social behaviors***
- ❑ ***Efficient 5G and IoT integration through innovative mobile-cloud, cloudlet, fog computing,*** ... approaches

Now some practical examples to start lightweight 😊 with the course and, most relevant, to stimulate your creativity (not only apps and AppStores...)



Monitoring Info Sharing in Vehicular Networks: MobEyes (1)

MobEyes

<http://netlab.cs.ucla.edu/cgi-bin/usemod10/wiki.cgi?MobEyes>

- Vehicles perform **opportunistic sensing** of urban environment and keep sensed data locally

- **Collaborative dissemination of metadata** based on local autonomous decisions

- Possibility of **emerging behaviors** to satisfy **application-specific requirements** (e.g., query completeness, response time, overhead, ...)

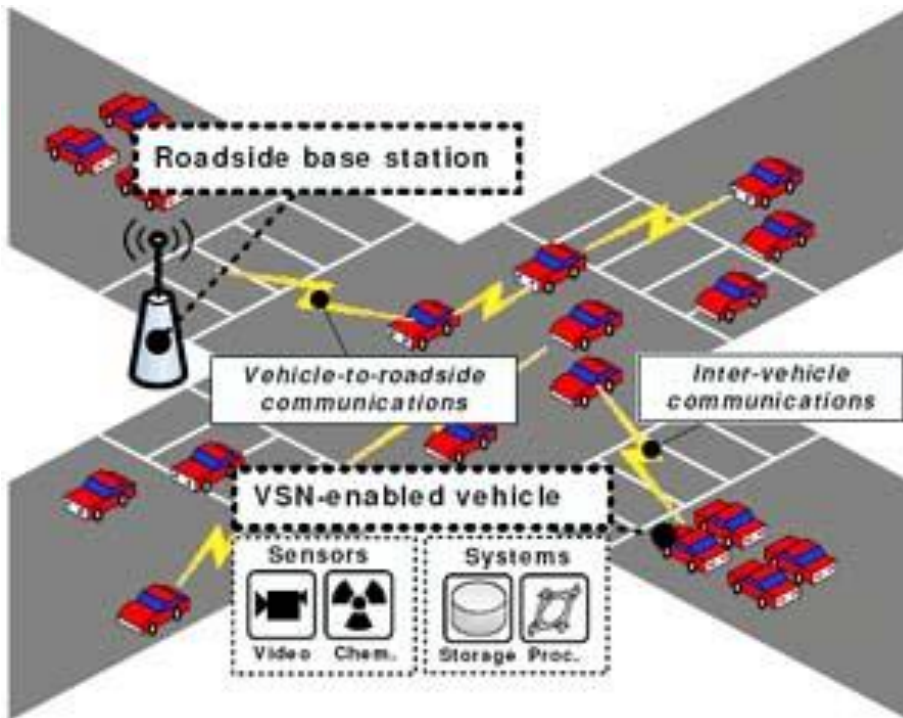



MobEyes (2): Basic Idea

Urban monitoring through vehicular networks of opportunistic and autonomous sensors

- ❑ Opportunistic meetings of “regular” vehicles equipped with sensors and wireless communications
- ❑ Sensor mobility is “**not-directed**”

Notable differences wrt WSN:

- ❑ Less stringent constraints on memory, storage, and **power consumption**
- ❑ Wide-scale deployment

Application scenario:

- ❑ Post-crime investigation (e.g., after terrorism attack)
- ❑ Vehicles with A/V sensors
- ❑ **Metadata summaries**

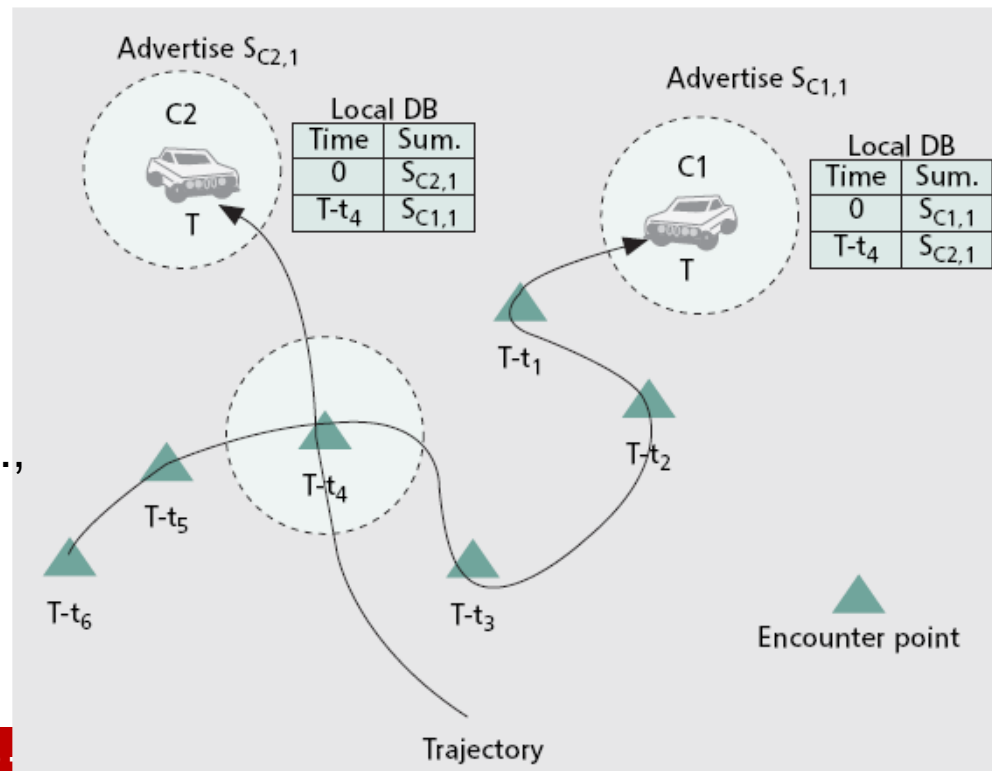



MobEyes (3): Basic Idea

How to induce the desired **emerging behavior** with **minimal and lightweight** management operations?

❑ Innovative protocols for **summary diffusion**

- Single-hop/k-hop passive diffusion
- Single-hop active diffusion

❑ Innovative protocols for **summary harvesting**

- ❑ Bloom filters adoption
- ❑ **Adaptive tuning** of protocols depending on **estimations/predictions over local properties**, e.g., node density
- ❑ Extensive **simulation work** in realistic deployment scenarios

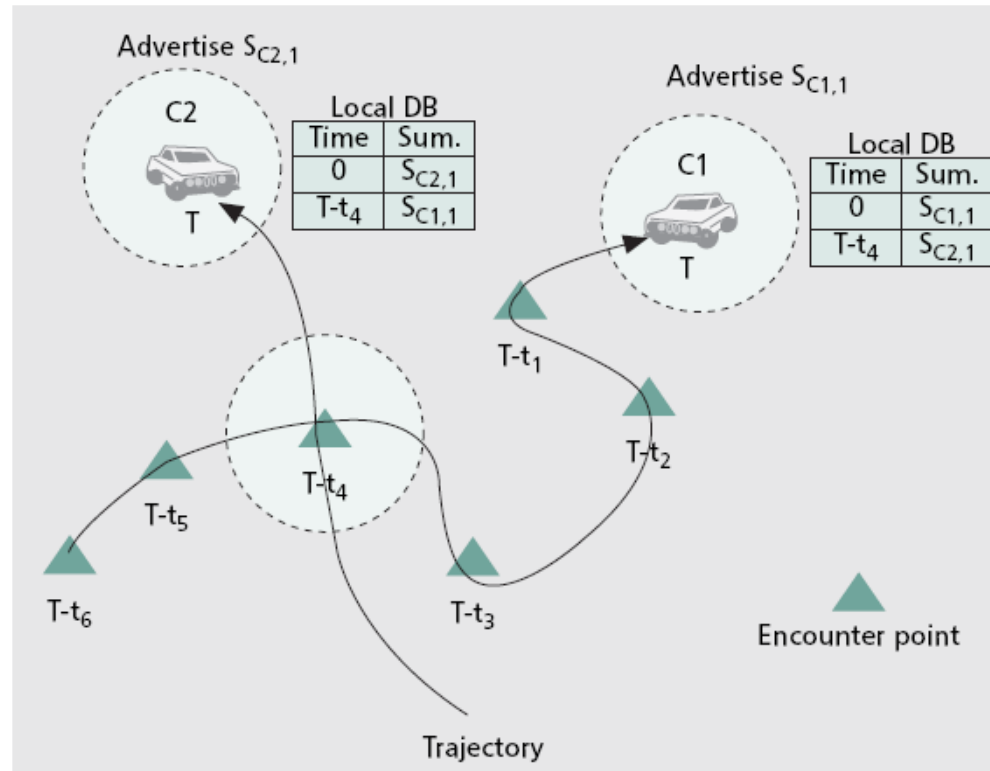



MobEyes (4): Protocols, Tradeoffs, and Bio-inspiration

Not only adaptive tuning of protocols for **summary diffusion and harvesting**

➡ Goal of **best tradeoff** between **limited overhead limitato and app-specific requirements** (latency, completeness, ...) in wide-scale environments

How to **coordinate multiple agents** for metadata harvesting? Need for **minimal explicit coordination and minimal overhead**

Bio-inspired Protocols

- ❑ **Metadata density** (prop. vehicle density) and **datataxis** (inpired by chemotaxis di *E.coli*)
- ❑ **Differentiated foraging** (*Levy jump, biased jump, constrained walk, ...*)
- ❑ **Conflict resolution** (via *stigmergy, ...*)

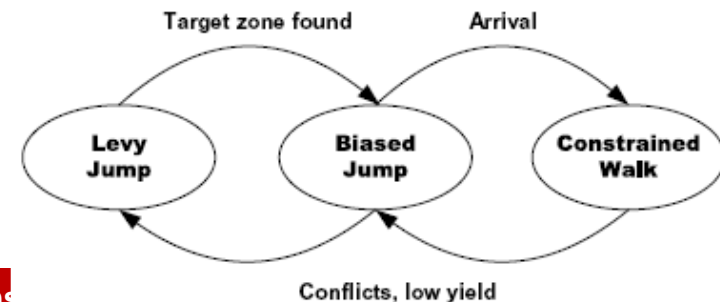



Social Sharing of Connectivity Resources: RAMP (1)

Multi-hop Multi-path Heterogeneous Connectivity (MMHC)

<http://lia.disi.unibo.it/Research/MMHC/>

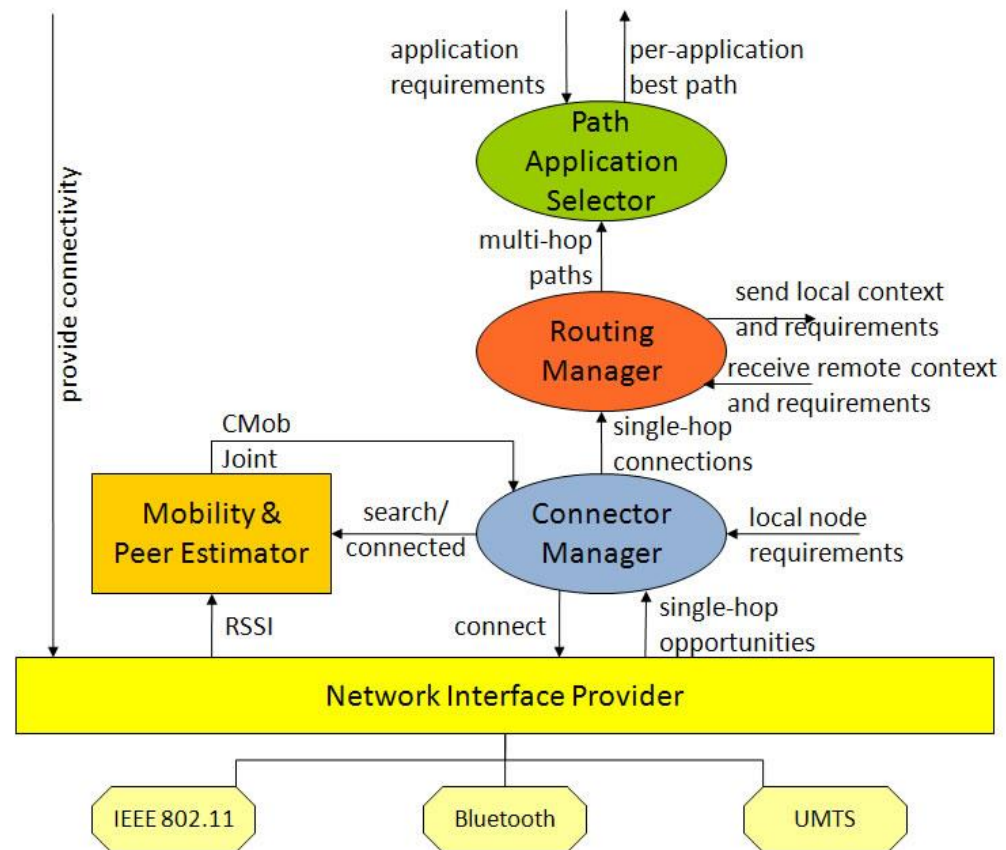
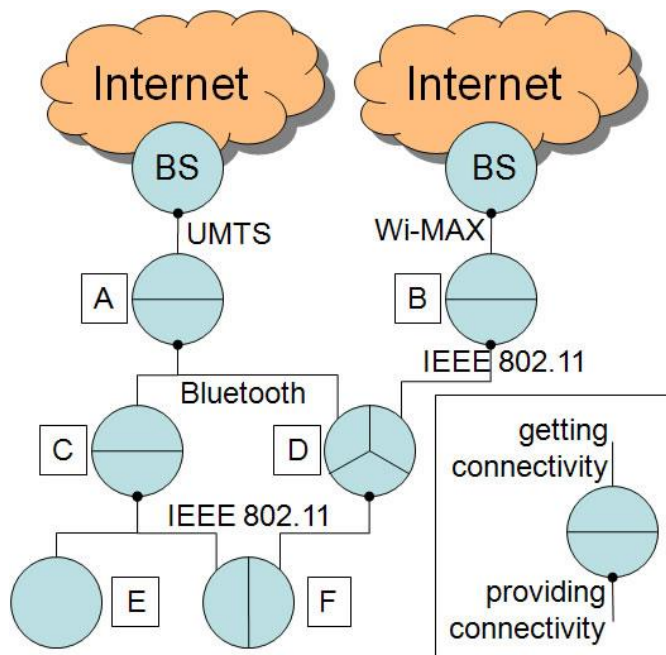



Social Sharing of Connectivity Resources: RAMP (2)

- ❑ Exploitation of **multiple wireless interfaces at the same time** in different het multi-hop paths, managed at the application level
- ❑ **Incentives to collaborate** and to share resources
- ❑ Based on innovative and lightweight **context indicators**, e.g., related to predictions of **joint mobility**, predictions of **throughput**, battery consumption, belonging to **social groups**, ...

Additional info about MMHC/RAMP:

- ❑ <http://lia.disi.unibo.it/Research/MMHC/>
- ❑ <http://lia.disi.unibo.it/Research/RAMP/>
- ❑ P. Bellavista, P. Gallo, C. Giannelli, G. Toniolo, A. Zoccola: “Discovering and Accessing Peer-to-peer Services in UPnP-based Federated Domotic Islands”, *IEEE Transactions on Consumer Electronics*, Vol. 58, No. 3, pp. 810-818, Aug. 2012
- ❑ P. Bellavista, A. Corradi, C. Giannelli: “Middleware for Differentiated Quality in Spontaneous Networks”, *IEEE Pervasive Computing*, Vol. 11, No. 3, pp. 64-75, March 2012



Social Sharing of Connectivity Resources: RAMP (3)

Real Ad-hoc Multi-hop Peer-to-peer (RAMP)

Impromptu interconnection of fixed and mobile nodes

- Not only to the purpose of Internet connectivity (Always Best Connected - ABC), but also to support users' willingness to **share contents, resources, and services**
- packet dispatching at the application layer over **het platforms**
- Management of **non-coordinated IP addressing spaces**

RAMP supports the creation and management of **spontaneous networks**

- **multi-hop** end-to-end connectivity
- users invoke and offer services (peer-to-peer)
- **API** to support the **development of novel services** in a simplified way

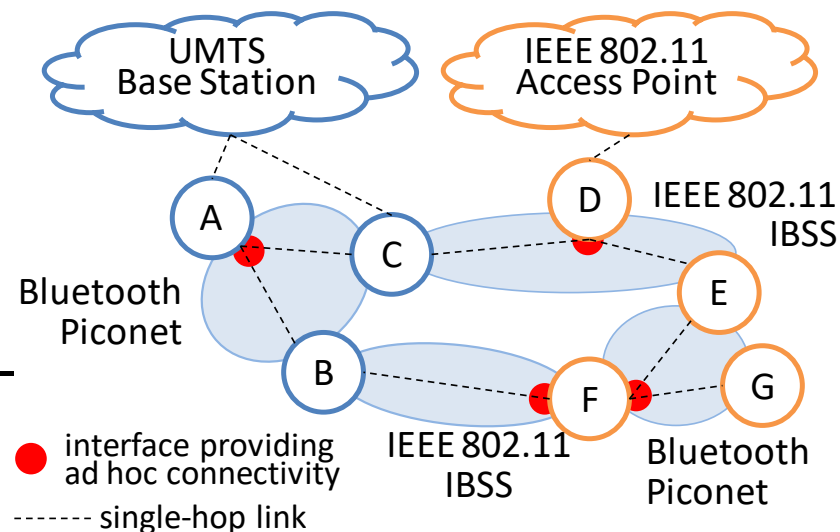



Application-specific Routing

NRBT

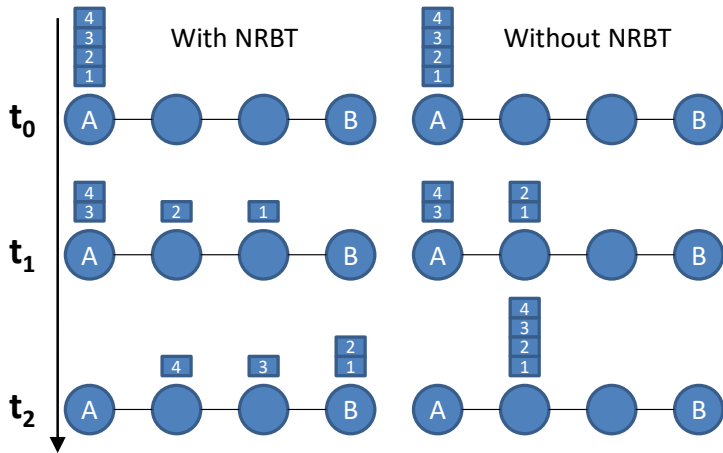

RPS

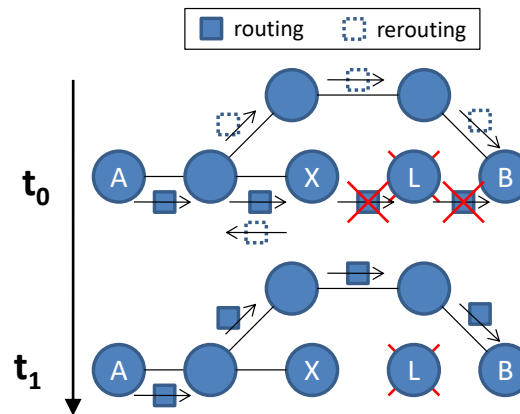

HRMD

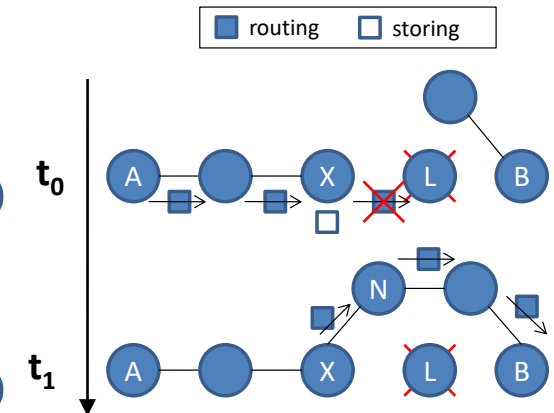

Application developers can specify delivery strategies with **per-packet granularity**

- **Non Reliable Bulk Transfer (NRBT):** *high performance*, low overhead, low reliability. Based on packet splitting (“large” packets, e.g., for file sharing)
- **Reliable Packet Streaming (RPS):** *to reduce disconnection issues*, (limited) usage of additional resources on participating nodes (many small packets, e.g., for multimedia streaming)
- **Highly Reliable Message Delivery (HRMD):** maximum availability for *delay-tolerant services* but at the expense of memory consumption (delivery of critical messages)



Application-layer Multimedia Re-casting

1) Nodes perform end-to-end **cooperative splitting** of multimedia paths into different segments

- reduced traffic on intermediary nodes

2) Nodes perform **cooperative monitoring of stream quality** (packet loss, jitter, ...) and **dynamically adapt** traversing flows (priority-based video frame dropping)

- **fine-grained and per-segment** management to reduce needed throughput close to dynamically identified bottlenecks

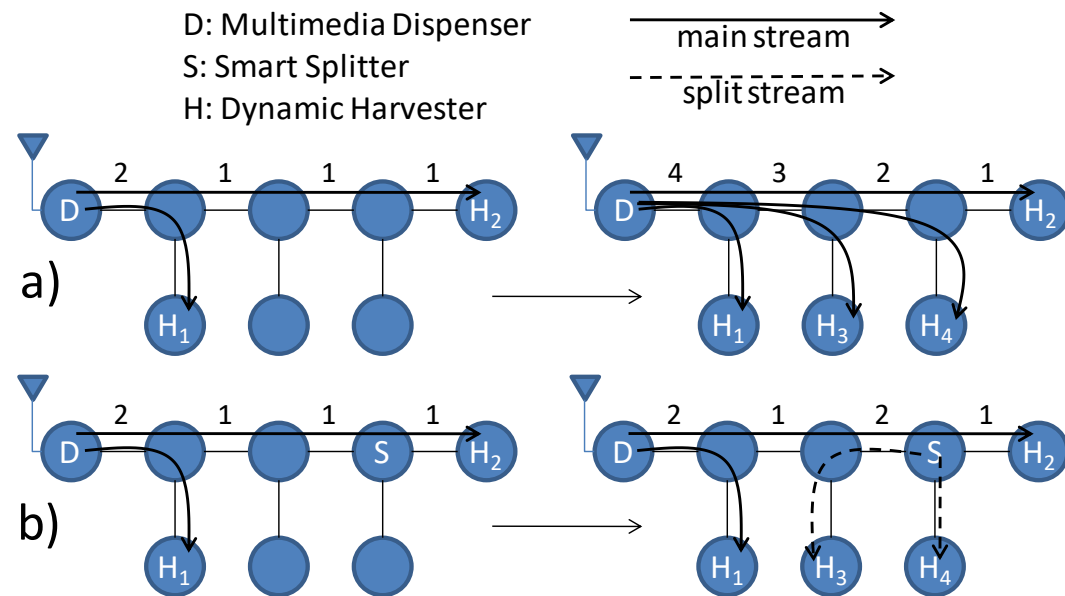

Industry 5.0: quale ruolo per gemelli digitali e intelligenza distribuita?

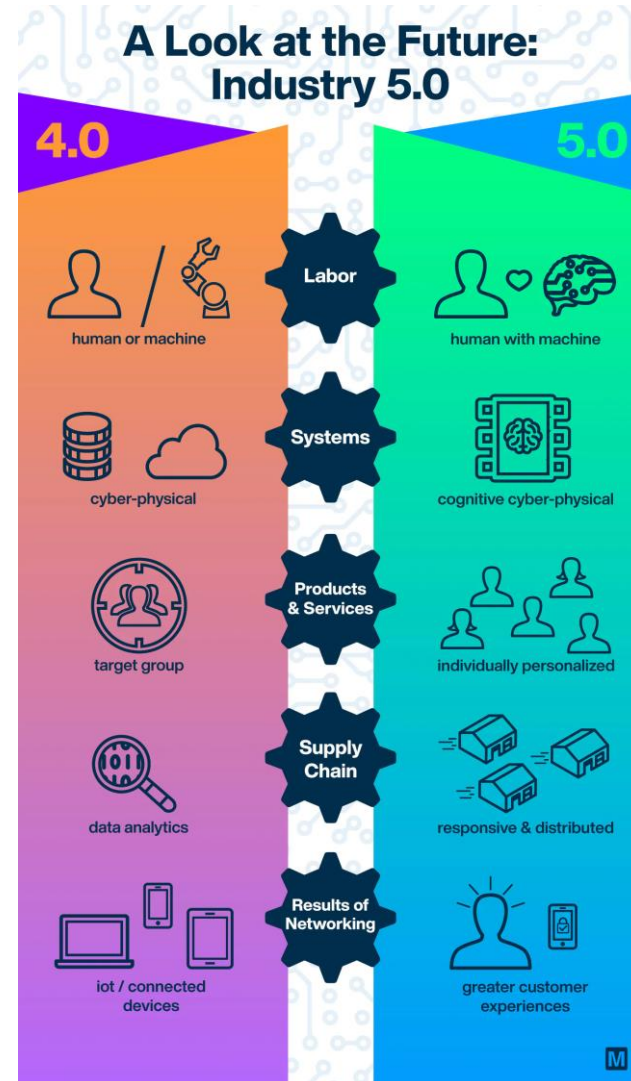
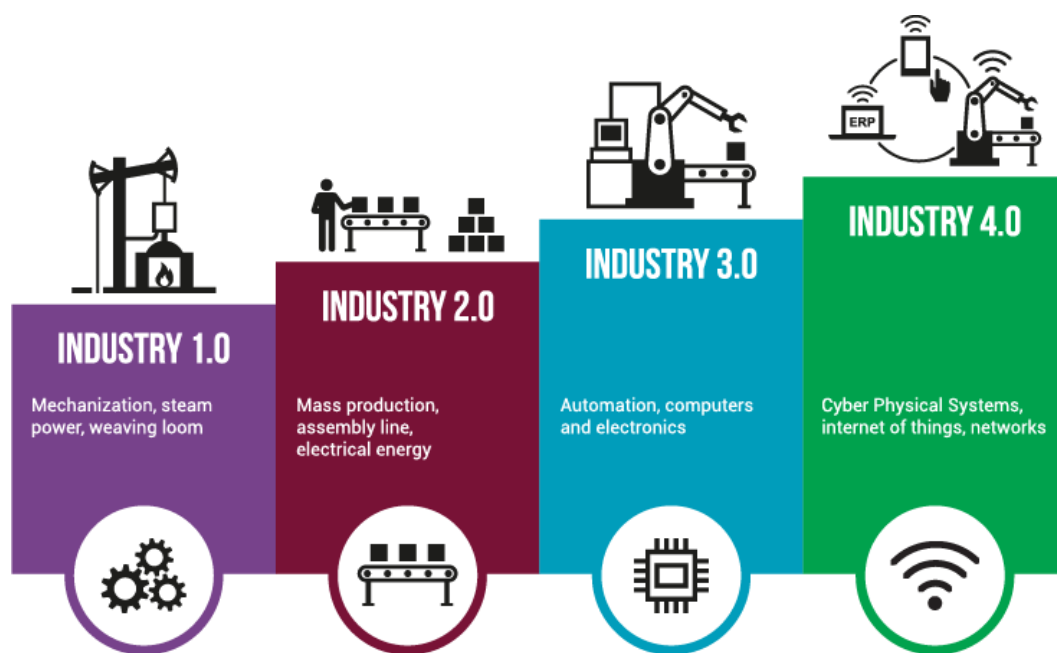

How do Digital Twins fit in?

Digital Twins are part of the digitization strategy, they require:

- a **vision** on digitization
- purpose in the processes
- the means to operate it
- the **adaptivity** of the **organization**

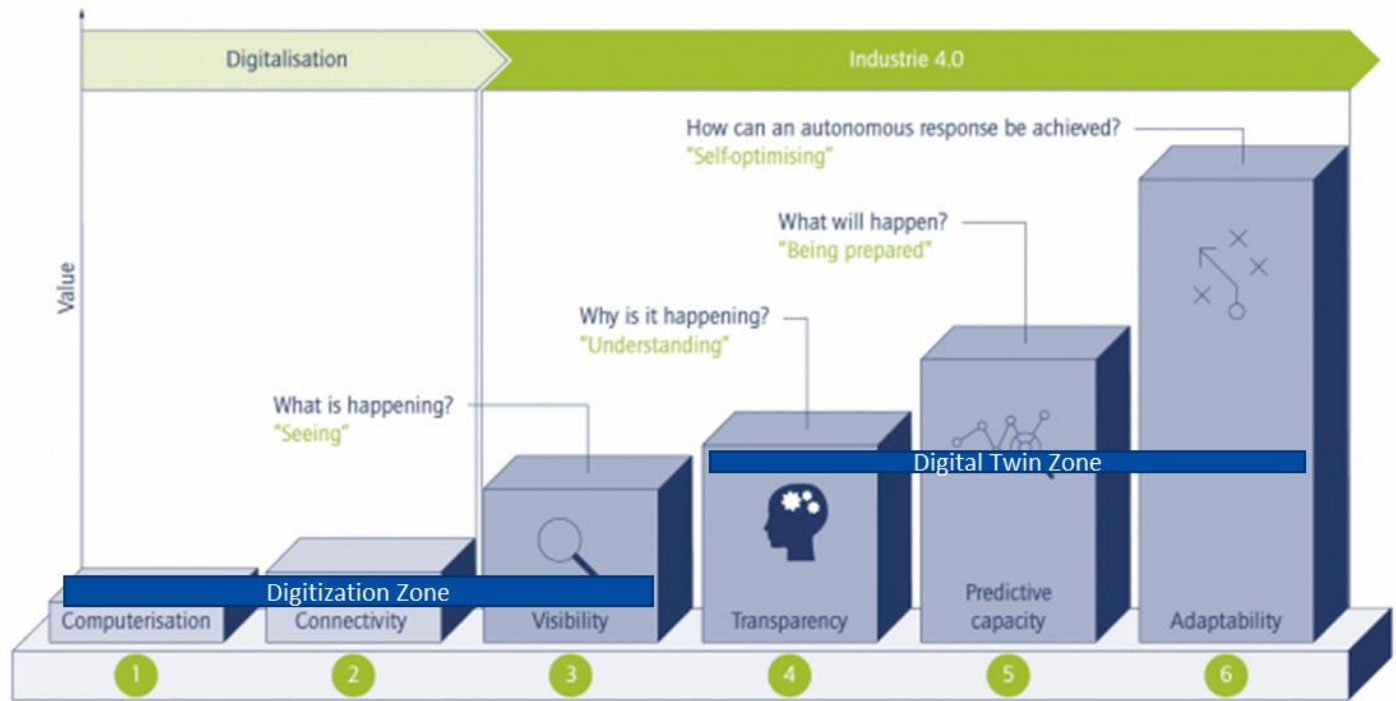

Figure 5: Stages in the Industrie 4.0 development path (source: FIR e. V. at RWTH Aachen University)



Testbed #5

Camp Nou

sport facility management and maintenance

The Digital Twin of the Nou Camp Nou Stadium in Barcelona

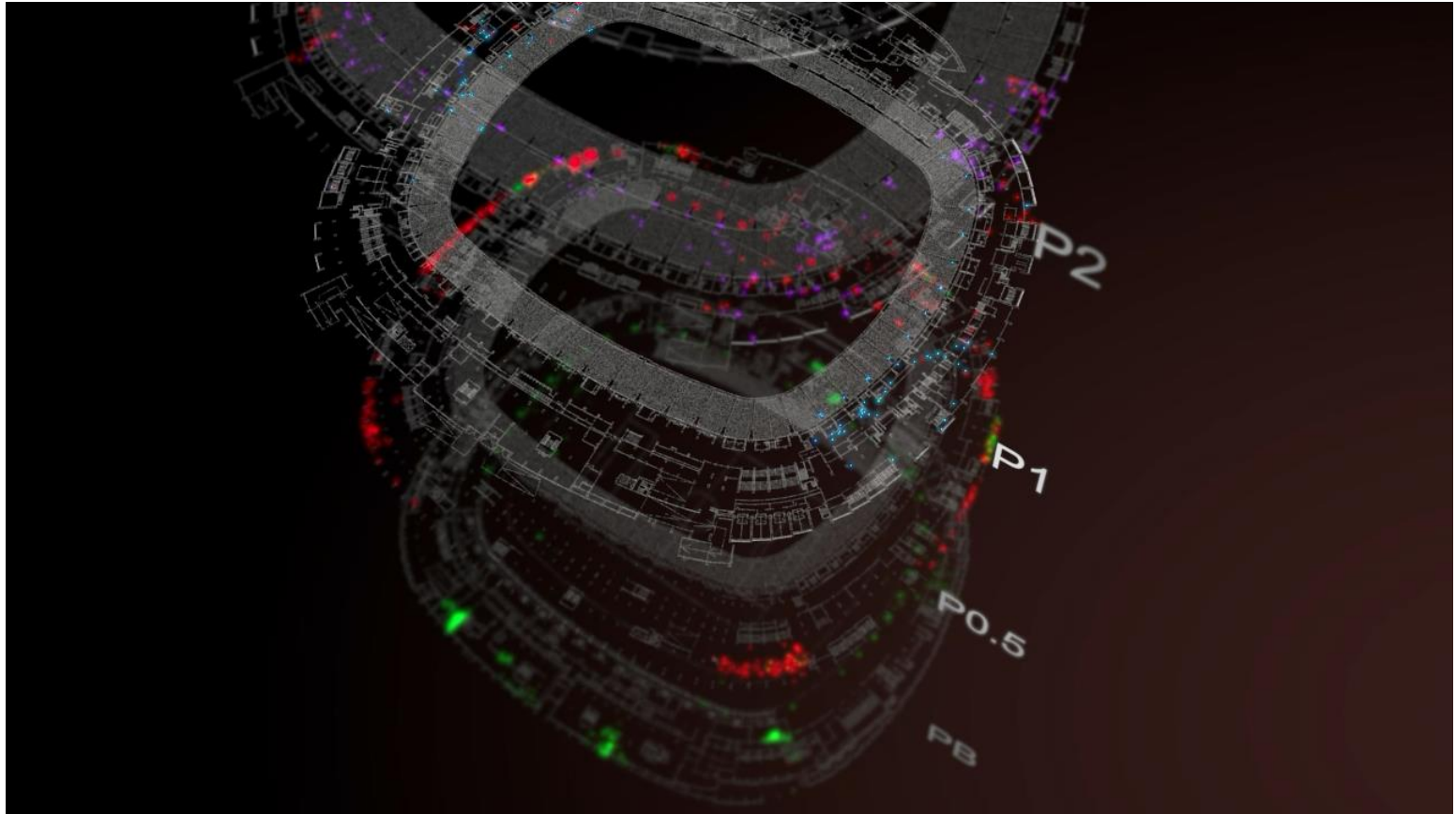

Digital Twin Distribuiti: Towards the Cloud Continuum

A Different Reality...

Due **latency, throughput, connectivity, cost** and **security** only a **restricted class of IoT/IIoT applications** that are **compatible** with the **cloud-centric mode**

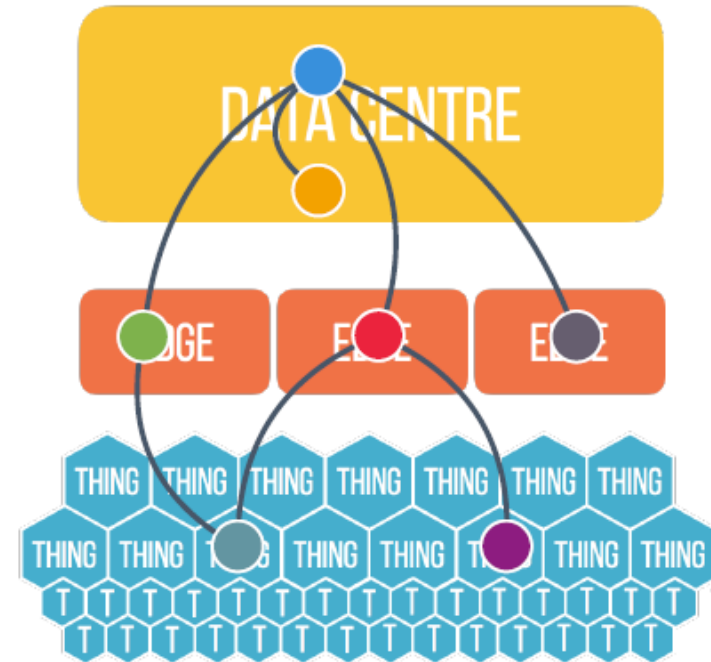
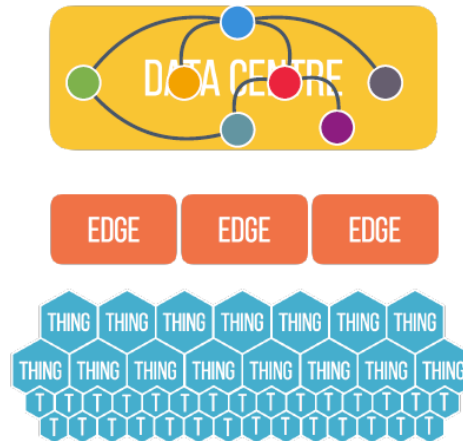

The Concept of DISTRIBUTED AND HYBRID DIGITAL TWINS

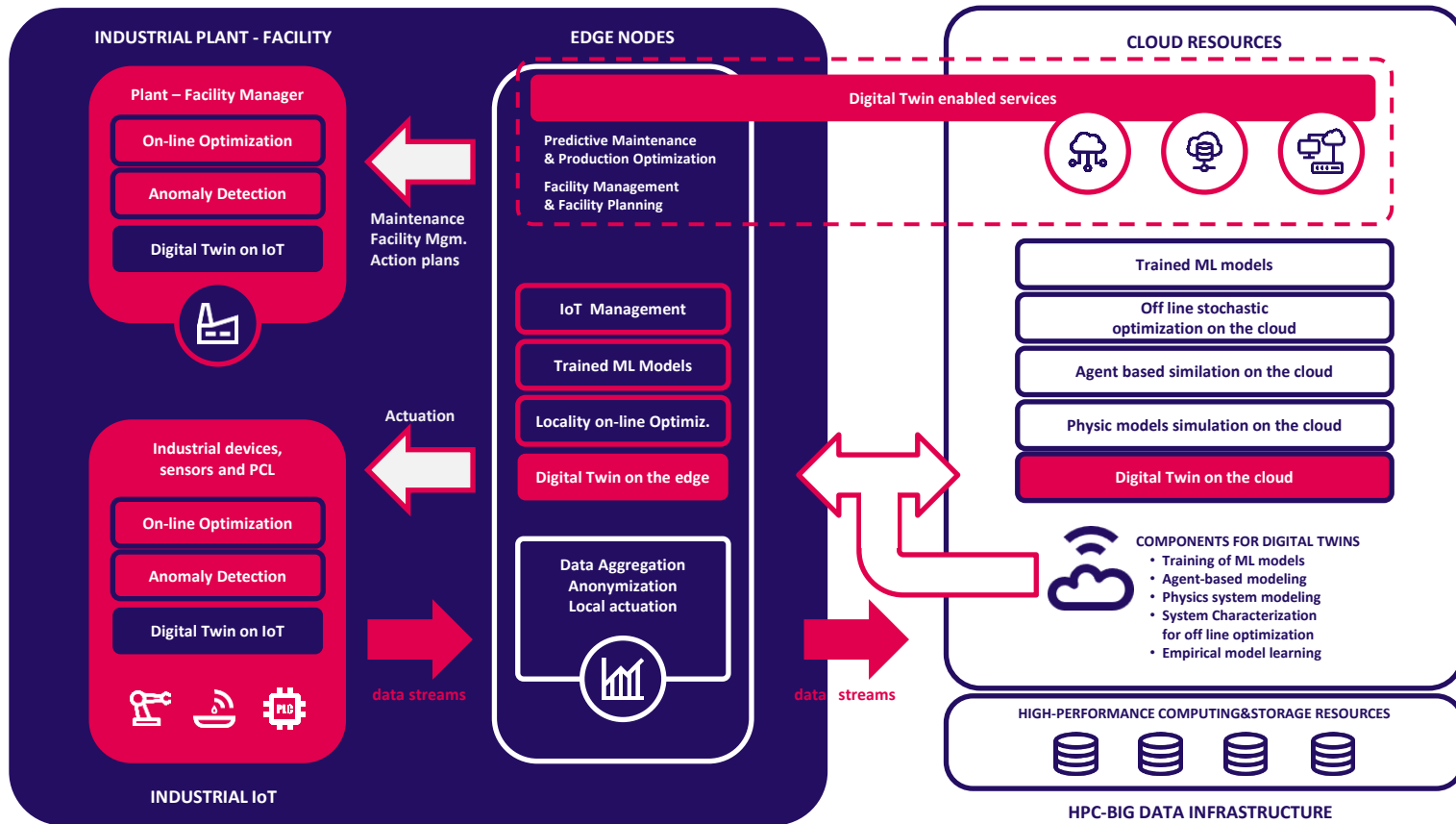

Training Hybrid and Distributed DT enabled by the CLOUD CONTINUUM

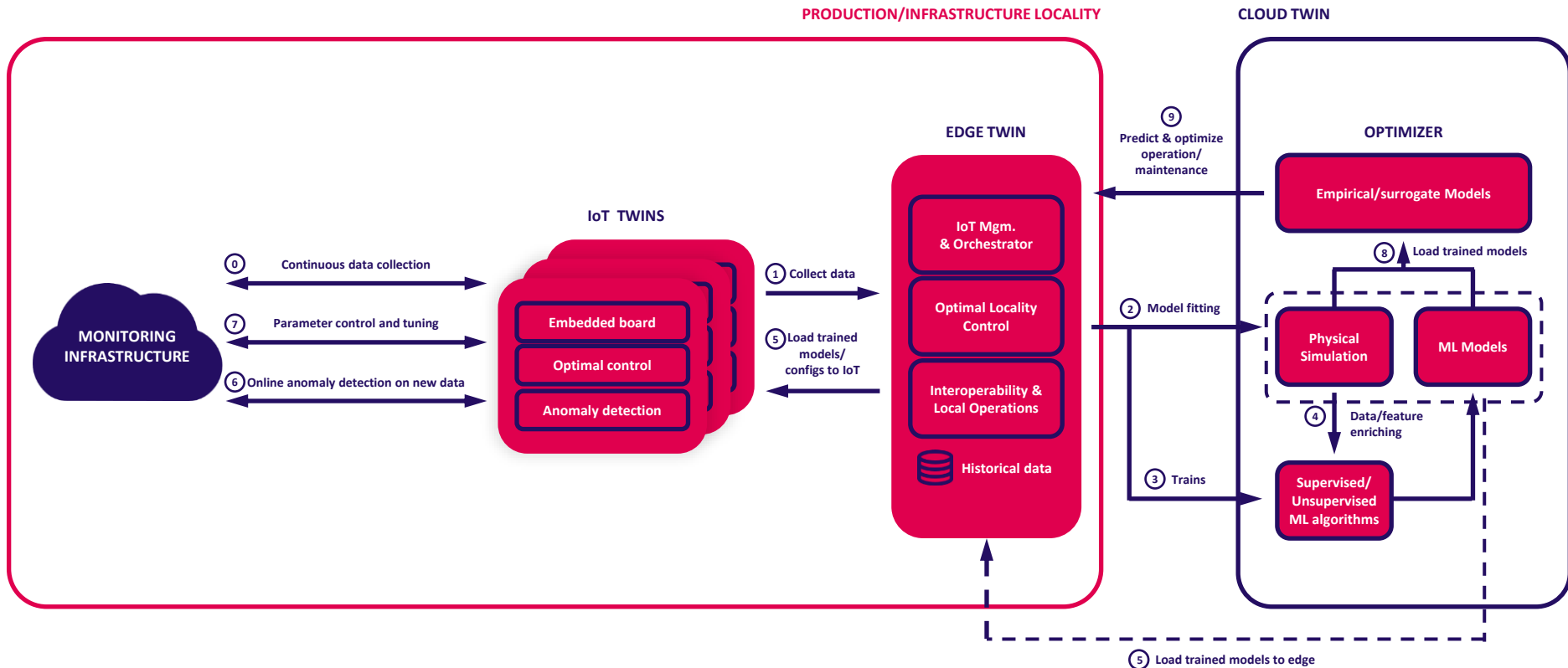



5G + Edge Cloud Computing

COSMOS Deployment: NYC Coverage Areas

- Pilot – planned for end of 2018
- Phase 1 in 2019, Phase 2 by 2020

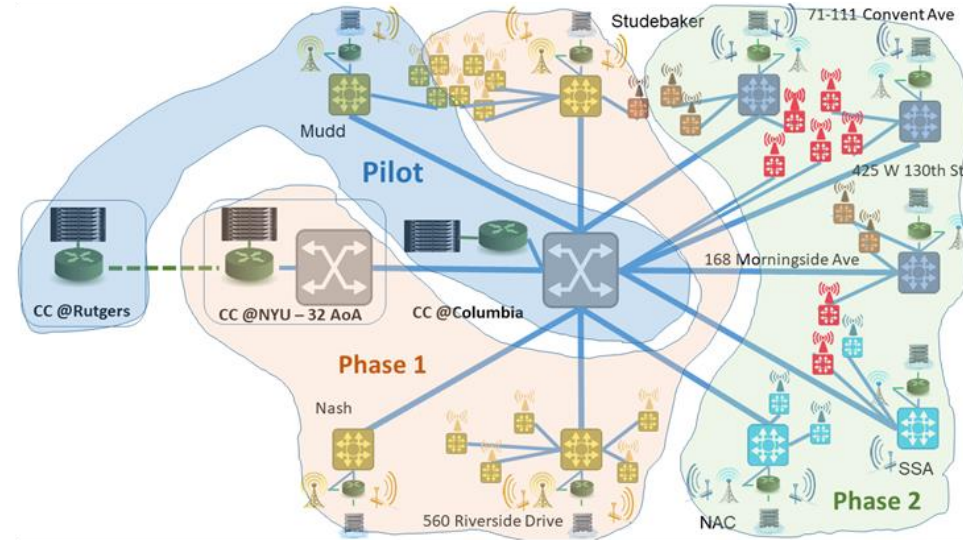

Mudd



Broadway



Amsterdam

- Phase 1 Columbia/CCNY – ~15-20 nodes
- Phase 2 – ~40 nodes



5G + Edge Cloud Computing

COSMOS Experiments: AR Applications

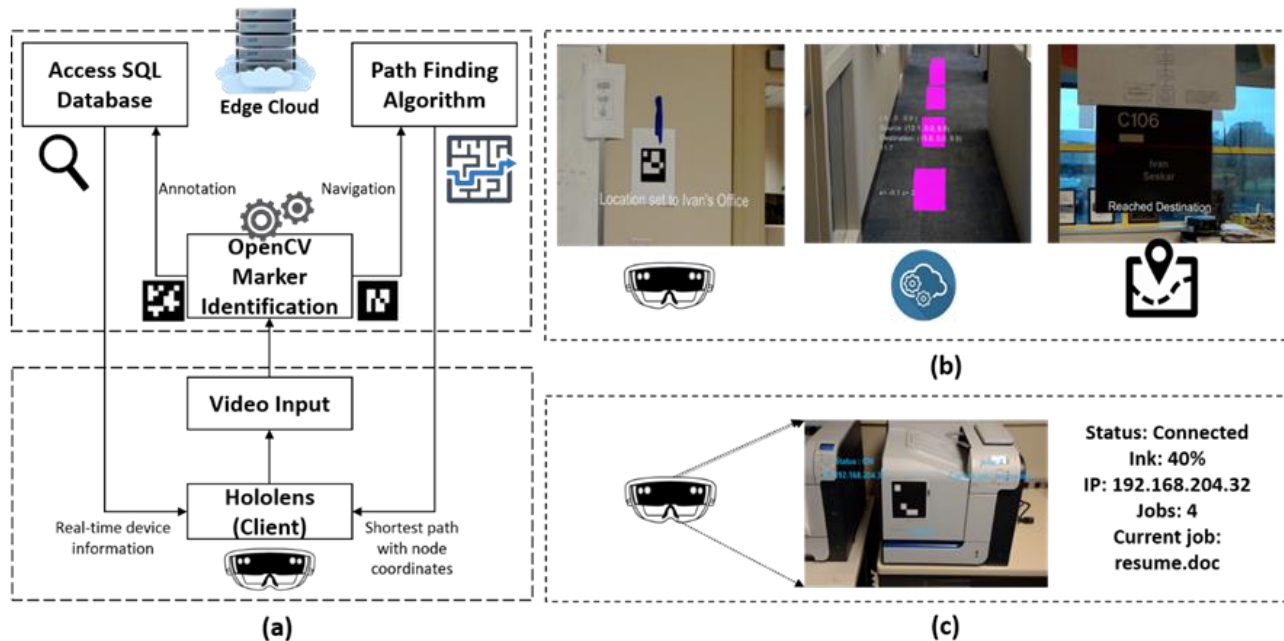

(a) AR application flow; (b) Smart meeting application using indoor navigation; (c) Annotation based assistance



5G + Edge Cloud Computing

COSMOS Experiments: Cloud Assisted Autonomous Vehicle

