



Cybersecurity: Access Control

Jocelyne Elias, Ozalp Babaoglu

Authorization and access control

- From authentication to authorization
 - Once subjects have been authenticated, the next problem to confront is *authorization* or *access control*
- Access control is a central element of computer security whose objectives are:
 - prevent unauthorized users from gaining access to resources,
 - prevent legitimate users from accessing resources in an unauthorized manner,
 - enable legitimate users to access resources in an authorized manner
- Set of *policies* and *mechanisms* that serve to decide if a particular ***subject*** is allowed to perform certain ***operations*** on certain ***objects***

- Access control is achieved through a set of *policies* and a set of *mechanisms* to enforce the policies
- Access control *policy* dictates what types of access are permitted, under what circumstances, and by whom
- Basic elements of access control are:
 - ***subject***: an entity capable of accessing objects
 - ***object***: a resource to which access needs to be controlled
 - ***access right***: describes the way in which a subject may access an object

Access control policy types

- ***Discretionary access control*** (DAC): access based on the identity of subjects and on access rules stating what subjects are (or are not) allowed to do on which objects. *Discretionary* because subjects decide to grant (or deny) access to other subjects
- ***Mandatory access control*** (MAC): access based on comparing *security labels* (which indicate how sensitive or critical objects are) with *security clearances* of subjects. *Mandatory* because security labels and clearances are set by the system and cannot be modified by subjects
- ***Role-based access control*** (RBAC): access based on the roles that subjects have within the system and on rules stating what accesses are allowed for subjects in given roles

Fundamental principles for security policies

- “Open design”
- “Economy of mechanism”
- “Fail-safe defaults”
 - By default, subjects have no access privileges over any object
- “Complete mediation” (reference monitor)
 - Objects cannot be accessed directly; all accesses must be controlled
- “Least privilege”
 - Subjects have the minimum access privileges that are necessary to carry out the operations that are required for that phase of execution

Fundamental principles for security policies

- ***Least Privilege***: every subject should operate using the *minimum* set of privileges (access rights) that are necessary to perform its task
 - Limits damage that can result from an accident or error
 - Limits number of privileged programs
 - Helps in debugging
 - Increases assurance
 - Allows isolation of critical subsystems
- *Least Privilege* enforced through a *reference monitor* that implements *complete mediation* — every access to every object is checked

- Let \mathcal{S} denote the set of *subjects*
- Let \mathcal{O} denote the set of *objects*
 - Note that objects can be active and acts as subjects
- Let α denote the set of *access rights* that subjects have on objects

Access control – Protection domains

- A *protection domain* is a set of objects and the set of access rights for each one
- Formally, it is a set of tuples
<object, set_of_access_rights>
- Subjects are associated with a given protection domain in which they operate
- The association between subjects and protection domains can be *static* or *dynamic*

Access control – Protection domains

- “Kernel mode” vs “User mode” in operating systems can be seen as two protection domains that control access to main memory
 - Normally processes operate in *user mode*
 - When they execute a system call, they switch to *kernel mode* and gain privileges that are required to carry out the system call
- This is an example of a dynamic association between subject and protection domain

Access Control Matrix model for DAC

- A model for *Discretionary Access Control* (DAC)
- Access Control Matrix
 - is a matrix M with domains as rows and objects as columns
 - each entry $M(i, j)$ contains the set of access rights α that domain D_i permits over object O_j
- When a new object is created
 - add a new column to the matrix
 - the contents of the column decided by the creator of the object

Access Control Matrix – Example

Assume each subject operates in their own protection domain

		OBJECTS			
		File 1	File 2	File 3	File 4
SUBJECTS	User A	Own Read Write		Own Read Write	
	User B	Read	Own Read Write	Write	Read
	User C	Read Write	Read		Own Read Write

Access Control Matrix – Example

- User *A* in domain D_2 editing *File₂*, user *B* in D_3 editing *File₃*
- Users *A* and *B* turn on “spelling corrector” function based on *File₄* which is a *dictionary*
- The *dictionary* is proprietary and should not be copied

		object			
		<i>File₁</i>	<i>File₂</i>	<i>File₃</i>	<i>File₄</i>
A	domain				
	D_1	read			
	D_2		read write	read	read
B	D_3			read write	read

But now *A* and *B* can make copies of the dictionary

Access Control Matrix – Example

- Introduce a new domain D_4 such that the dictionary can only be read in that domain and add new access right “switch”

		object				
		<i>File₁</i>	<i>File₂</i>	<i>File₃</i>	<i>File₄</i>	<i>D₄</i>
domain						
A	<i>D₁</i>	read				
	<i>D₂</i>		read write	read		switch
	<i>D₃</i>			read write		switch
B	<i>D₄</i>				read	

Access Control Matrix – Example

- But now users **A** and **B** cannot access the files they are editing (*File₂* and *File₃*)
- “Switch” not only changes domains but also copies the access rights from the source domain to the destination domain
- Since there may be multiple users that switch to the same domain, they are kept logically distinct by creating multiple instances of the domain
- This mechanism effectively implements the “principle of least privilege”

Access Control Matrix – Example

		object				
		<i>File₁</i>	<i>File₂</i>	<i>File₃</i>	<i>File₄</i>	<i>D₄</i>
domain						
	<i>D₁</i>	read				
<i>A</i>	<i>D₂</i>		read write	read		switch
<i>B</i>	<i>D₃</i>			read write		switch
<i>A</i>	<i>D₄</i>		read write	read	read	
<i>B</i>	<i>D₄</i>			read write	read	

- As a global table:
 - store the matrix as a 2-dimensional array (table) with entries that are **<set_of_access_rights>**
- Advantages:
 - simple to implement
- Drawbacks:
 - table can be huge
 - difficult to maintain in a dynamic system where domains and objects are added/deleted and access rights change over time

Access Control Lists

- Access Control List (ACL)
 - the table is stored “per column”
 - with each object, associate a list of tuples that specify access rights for each domain
<domain, set_of_access_rights>
- Optimizations for reducing the length of the list
 - include only domains that have access rights different from a default (e.g., no access)
 - group domains into a (small) number of sets and define access rights only for them
- ACL act like the “guest list” for a party that is checked by a guard at the door to decide who gets to enter

Access Control List

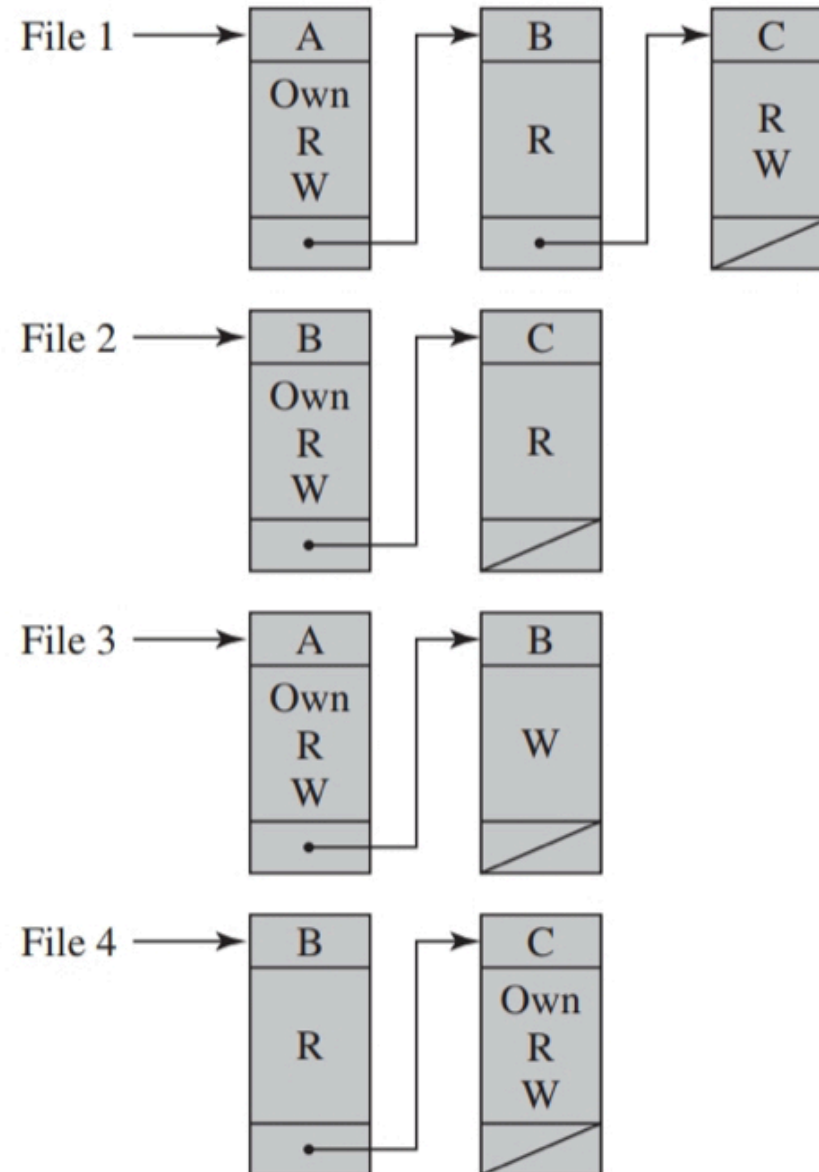

Access Control Lists

- Unix example:

```
babaoglu% ls -l /etc/passwd
```

```
-rw-r--r-- 1 root wheel 7579 Jan 1 2020 /etc/passwd
```

- Unix has only 3 domains: owner, group, others

■ Capability

- the table is stored “per row”
- every domain is associated a list of access “rights”
<object, access_rights_for_object>
- such a tuple is called a *capability*

■ Who maintains capabilities?

- processes that “present” them to exercise the access rights over the object
- capabilities act like keys to open locks protecting objects or invitations that convince “bouncers” guarding a party

Capability

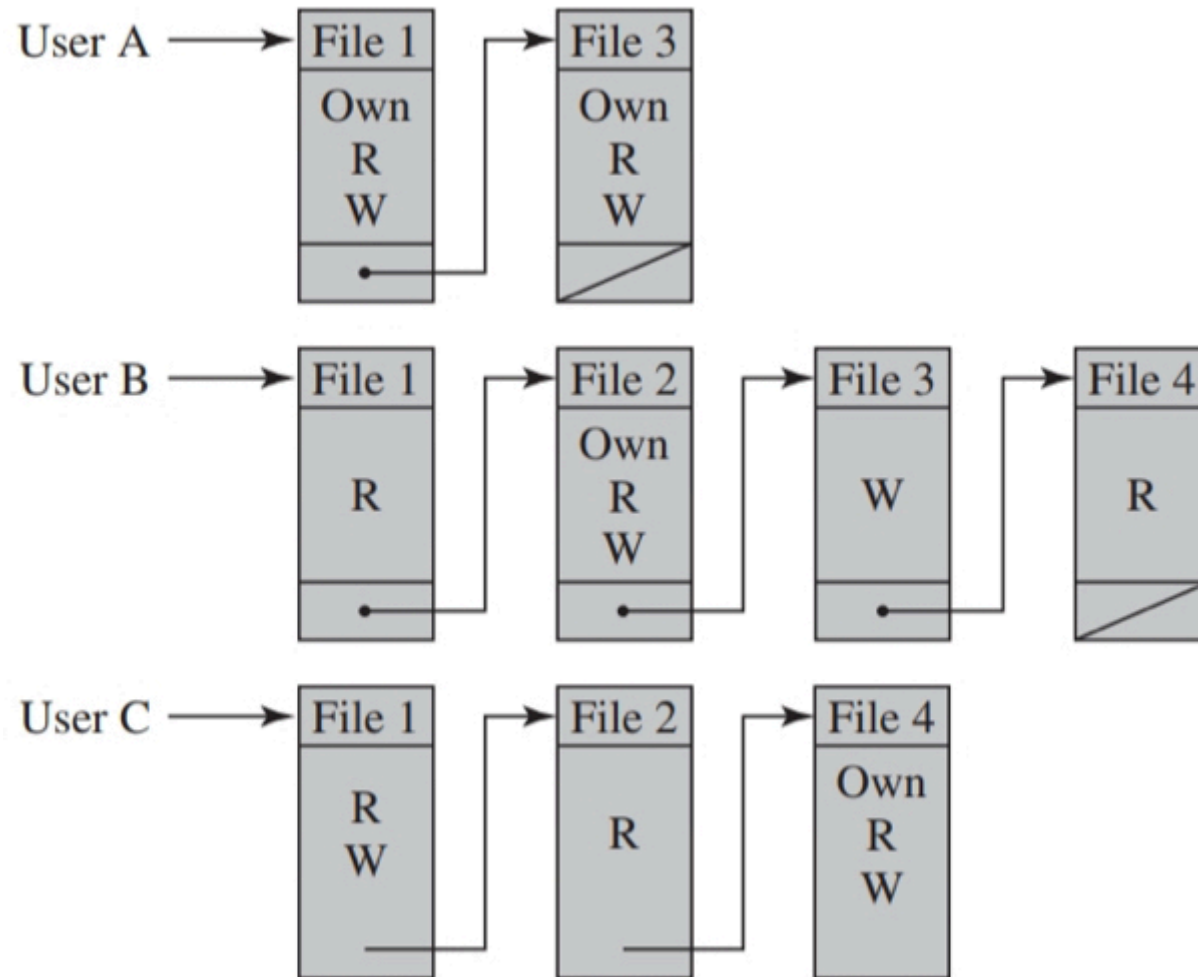

For the capability mechanism to function, we must guarantee that:

- processes not be able to forge fake capabilities
- the object (reference monitor) is able to recognize if a capability is fake or authentic
- processes may be permitted or not to copy or transfer their capabilities

Capability implementation

- Capabilities can be implemented using public-key cryptography
- Processes are given capabilities in the form of triples:
<object, access_rights_for_object, unique_code>
after being signed with the private key of the object
- Processes can store and observe capabilities but cannot modify them since they cannot sign the modified version because they do not have the object's private key (similar to certificates)

- When a process needs to access a resource, it presents to the object the capability it holds for that object
- When an object is presented a capability,
 - it verifies the signature,
 - checks its name,
 - checks the control code,
 - checks that the current access is permitted by the access rights listed in the capability
- N.B. the capability can be *copied* and *transferred* to another process but cannot be modified

Revocation of access rights

- Revocation can be:
 - immediate or delayed
 - selective or general
 - partial or total (all access rights or some)
 - temporary or permanent
- Revocation in ACL-based systems
 - Easy — it suffices to update the access rights found in the list associated with the object
- Revocation in capability-based systems
 - Difficult — since access rights are not held at the object but are distributed to processes through capabilities, modifying them requires that we first locate them — may be difficult or impossible

Revocation of access rights

- Time-limited capabilities:
 - capabilities have an “expiration date” after which they need to be renewed
 - by not renewing capabilities, we can achieve (delayed) revocation
- Indirect capabilities
 - capabilities do not point directly to objects but to entries in intermediate tables that point to objects
 - by modify the entries in the intermediate table, we can simulate (immediate) revocation

Access control example: UNIX file system

- Every object (resource) in UNIX is a **file** with a tree-structured naming scheme (e.g., `/usr/bin/spell`)

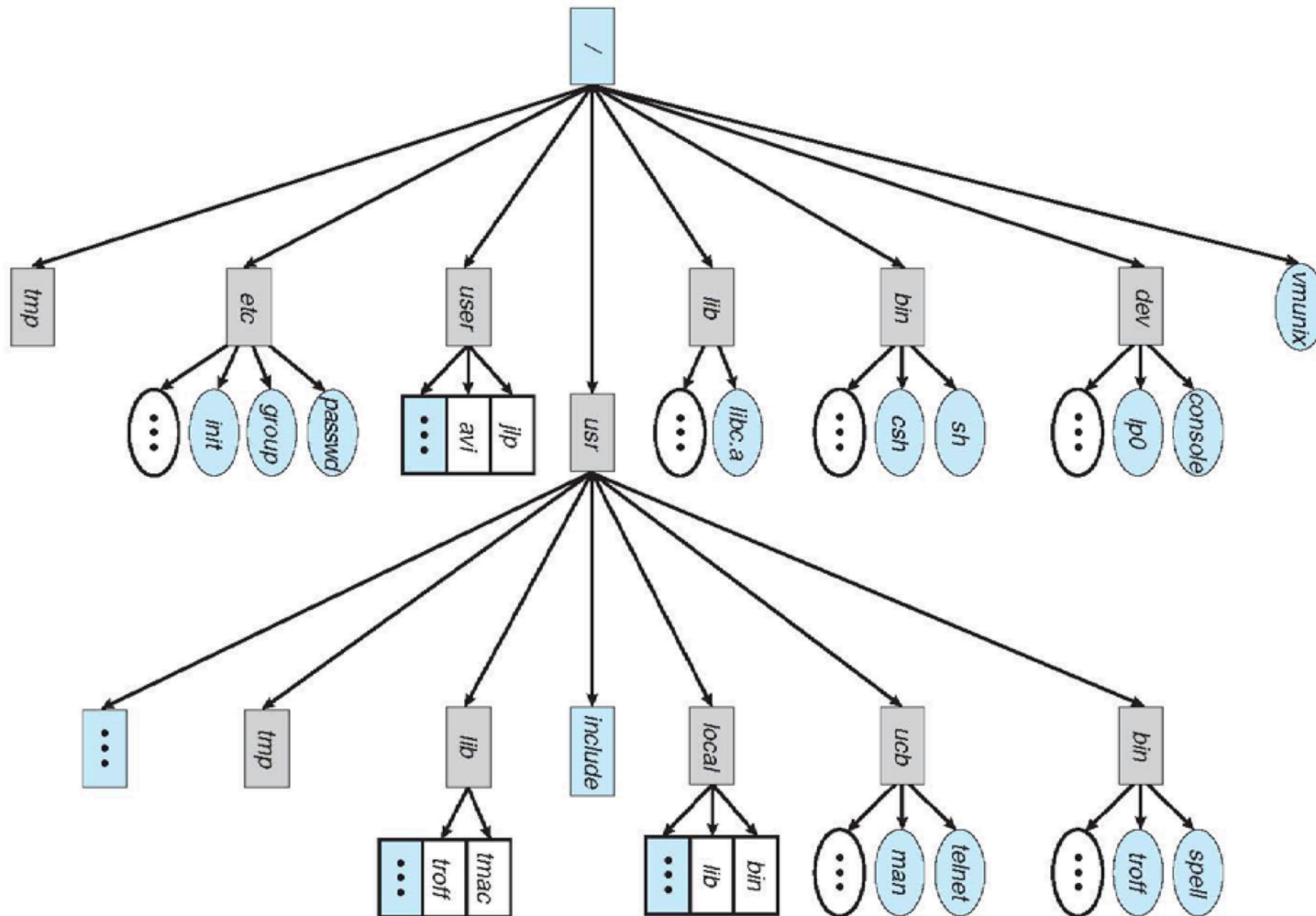

Access control example: UNIX file system

- Every file has:
 - owner — the user that created the file
 - group — a collection of users
- Every file has 9 bits of **access rights** corresponding to:
 - **r**ead, **w**rite, **e**xecute for *owner*
 - **r**ead, **w**rite, **e**xecute for *group*
 - **r**ead, **w**rite, **e**xecute for *other*
- Examples:
 - **rw-r--r--** (644)
 - **rw-r-xr-x** (755)

Access control example: UNIX file system

- Users and groups are identified using integers found in the password file

- *user-id*

- *group-id*

```
mezzina:x:501:1000:Leonardo Mezzina:/home/mezzina:  
trotter:x:502:1000:Guido Trotter:/home/trotter:
```

- Each process created by the user (to execute commands) inherits her *user-id* and *group-id* as the process *real-user-id* and *real-group-id*
- When a process creates a new file, its owner and group are set to the *real-user-id* and *real-group-id* of the process creating it
- Subsequently, the file's owner can be modified through the command

chown newusername file(s)

- Typically disabled (limited to root) in systems that maintain file quotas

Real vs Effective User ID

Each process has several IDs associated with it:

- *real-user-id, real-group-id*

- identify the real user and group that launched the process
- these values are read from the passwd file
- do not change during the execution of the process

- *effective-user-id, effective-group-id*

- set dynamically during the execution of the process through the **setuid** mechanism
- are used to determine the *access rights* of the process when interacting with the file system

Hybrid access control

- Often, systems are not *pure* ACL-based or *pure* Capability-based
- **Hybrid access control** combines ACL and Capability mechanisms to obtain the advantages of both:
 - Access control based on identity — ACL
 - Ease of revocation — ACL
 - Efficiency of access — Capability

Hybrid access control example: UNIX

- Open system call
 - `int open(const char *pathname, int flags);`
- where flags is one of
 - `O_RDONLY`
 - `O_WRONLY`
 - `O_RDWR`
- The `open ()` call checks that the named file exists, that the access requested (*flags*) is allowed for *effective-user-id* and *effective-group-id* of the executing process and returns a (small) integer called a *file descriptor*
- For execute, there is a separate system call
 - `execv("/bin/cat", args);`

Hybrid access control example: UNIX

- The *file descriptor* returned by the `open()` system call is an index into a *File Descriptor Table* maintained in kernel space

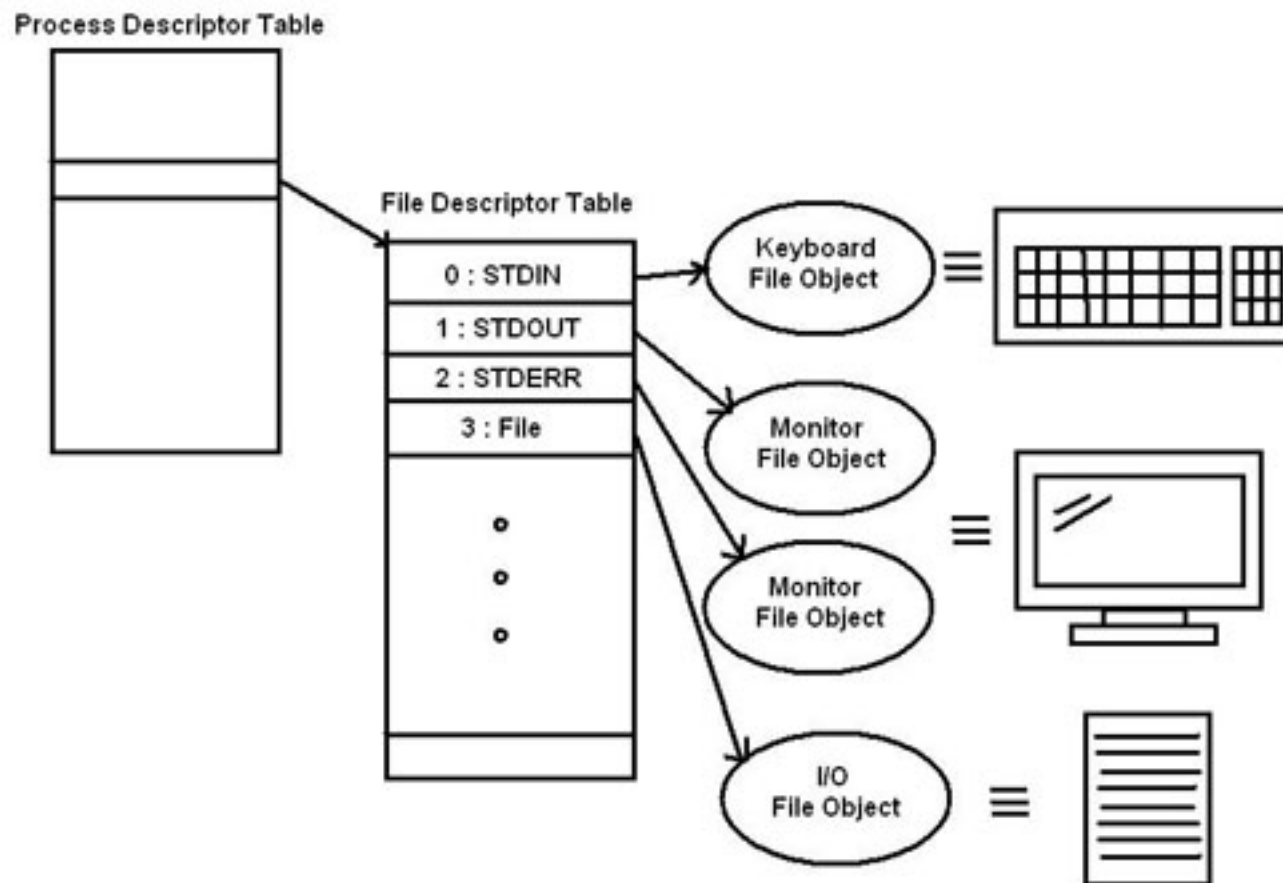

Hybrid access control example: UNIX

- The *File Descriptor Table* is nothing more than a list of *capabilities* corresponding to the files that can be accessed by the process
- A process can use a capability by pointing to it in the *File Descriptor Table* but cannot modify it
- After a file has been **opened**, it can be accessed as many times as necessary through the system calls **read()** and **write()** *without any further checks*
- In this manner, the cost of verifying access (which is high since it requires reading data structures on disk) is paid only **once** and this cost is amortized over many (thousands, millions) of **read/write** calls that are fast (do not perform any access control checks)

Hybrid access control example: UNIX

```
int main()
{
    int fd;
    static char message[] = "Hello, world";

    fd = open("foo.bar", O_WRONLY);
    if (fd == -1)
    {
        perror("foo.bar");
        exit (1);
    }
    else
        write(fd, message, sizeof(message));
}
```

- In addition to *real-user-id*, *real-group-id*, *effective-user-id* and *effective-group-id*, each process has a *saved-user-id* and *saved-group-id* that contain copies of the effective user id and effective group id that existed at the time a **setuid** program is executed
- *saved-user-id* and *saved-group-id* allow the process to return to its effective user/group id once the execution of the **setuid** program terminates

Set-user-id, Set-group-id

- Normally:
 - *effective-user-id* and *real-user-id* are the same
 - *effective-group-id* and *real-group-id* are the same
- At the time an executable file with the ***set-user-id*** bit of its permissions set is executed, the following occurs:
 - *saved-user-id* set to *effective-user-id*
 - *effective-user-id* set to *user id* of the file's owner
- At the time an executable file with the ***set-group-id*** bit of its permissions set is executed, the following occurs:
 - *saved-group-id* set to *effective-group-id*
 - *effective-group-id* set to *group id* of the file's owner

Set-user-id, Set-group-id

- These mechanisms allow any user to run the executable with the permissions of the executable's owner or group
- New permissions remain in effect only during the course of the execution
- When the execution terminates, permissions return to their previous state
- Allows a process to change its protection domain dynamically during its execution
- Can be used to implement "principle of least privilege"

Set-user-id example

- How to implement a command that allows users to change their passwords?
- A user *should* be able to change her own password, but should *not* be able to see (or modify) the passwords of others
- But in Unix, permissions are at the granularity of an entire file
- It is not possible to define permissions at the granularity of individual records (lines within the **/etc/passwd** file)
- To allow any user to modify her password, the permissions of the **/etc/passwd** file must be set to “read/write by all”
- But now anyone can see (and modify) the password of anyone else

Set-user-id example

- Use of the **setuid** mechanism to solve the password problem:
 - Root writes a command **/bin/passwd** that is owned by **root** with permissions **r-s--x--x** (the **setuid** bit is on)
 - The file **/etc/passwd** is owned by **root** with permissions **rw-----** (read/write root only)
 - When **/bin/passwd** is executed by a process, its *effective-user-id* changes to **root**
 - Therefore, the process can write the file **/etc/passwd** but only after having made all necessary checks implemented by the command **/bin/passwd**